

Heat Exchanger

High efficiency heat exchangers for fast and flexible heating for all types of installations



Products from Pahlén Pool System, for a trouble-free pool ownership.

For more information: www.pahlen.com



Made in Sweden

Heating - Heat exchangers



Pahlén pool heat exchangers for fast and flexible heating. A heat exchanger is used to transfer heat energy from one medium to another without the two media being mixed. All the models can be installed and connected to electric, firewood, pellets or oil-fired boilers, heat pump or solar panel systems. The heat exchangers are designed and made of materials that permit their use for a wide variety of needs and in many different types of installations.

Heating - Heat exchangers



Maxi-Flo

Made of acid proof stainless steel EN 1.4401 or titanium. Maxi-Flo is a tube heat exchanger with excellent heating properties and is simple to install.



Hi-Flow

Made of acid proof stainless steel EN 1.4401 or titanium. Hi-Flow is a spiral heat exchanger for installations that operate under high pressure.



Hi-Temp

Made of acid proof stainless steel EN 1.4401. Hi-Temp is a spiral heat exchanger made of fibreglass reinforced thermoplastic for extra durability, and a coil of acid proof stainless steel EN 1.4401.



Hi-Temp titanium

Made of titanium. Hi-Temp is a spiral heat exchanger made of fibreglass reinforced thermoplastic for extra durability, and a coil of titanium for salt water pools.



Aqua MEX

Made of acid proof stainless steel EN 1.4401 or titanium. Outer jacket of fibreglass reinforced thermoplastic. Aqua MEX is a heat exchanger which can be equipped with digital control and circulation pump.

Heating - Heat exchangers



Maxi-Flo titanium 75-200kW

Maxi-Flo titanium is a tube heat exchanger made of titanium for the most demanding installations where there is a high risk of corrosion. Titanium is ideal for swimming pools with salt water or when a salt chlorinator is used.

Titanium for maximum heat transfer. Connects to boiler, heat pump, solar panel system or other heat source. Suits all installations.

Maximum pressure secondary circuit (pool water) 75 kW is 5 bar/200 kW 4 bar and primary circuit (hot water) is 10 bar for both. Suitable for pools up to 1000 m³.

Features

- Titanium
- Twisted tubes for the heating medium
- Available in 75 and 200kW
- Suits all installations
- Mounted vertically



Maxi-Flo titanium is a tube heat exchanger with twisted tube pipes for optimal heating. Titanium is the ideal material when a salt chlorinator is used.

Technical data

Item no.	Type	kW	Capacity		Primary, hot water		Secondary, pool water	
			kBtu/h	kcal	l/min	press. drop H (m)	l/min	press. drop H (m)
11377	MFT260	75	260	64 488	35	0.9	300	1.8
11380	MFT680	200	680	172 000	95	0.1	600	3

Capacity at a temperature difference of 60°C

Dimensions

Item no.	Type	kW	Heating surface m ²	A	B	C	D	E	F	G	kg
11377	MFT260	75	0.77	139	Ø 129	1"	597	84	2"	167	9.8
11380	MFT680	200	2.11	201	Ø 196	2"	612	146	DN65	294	23.8

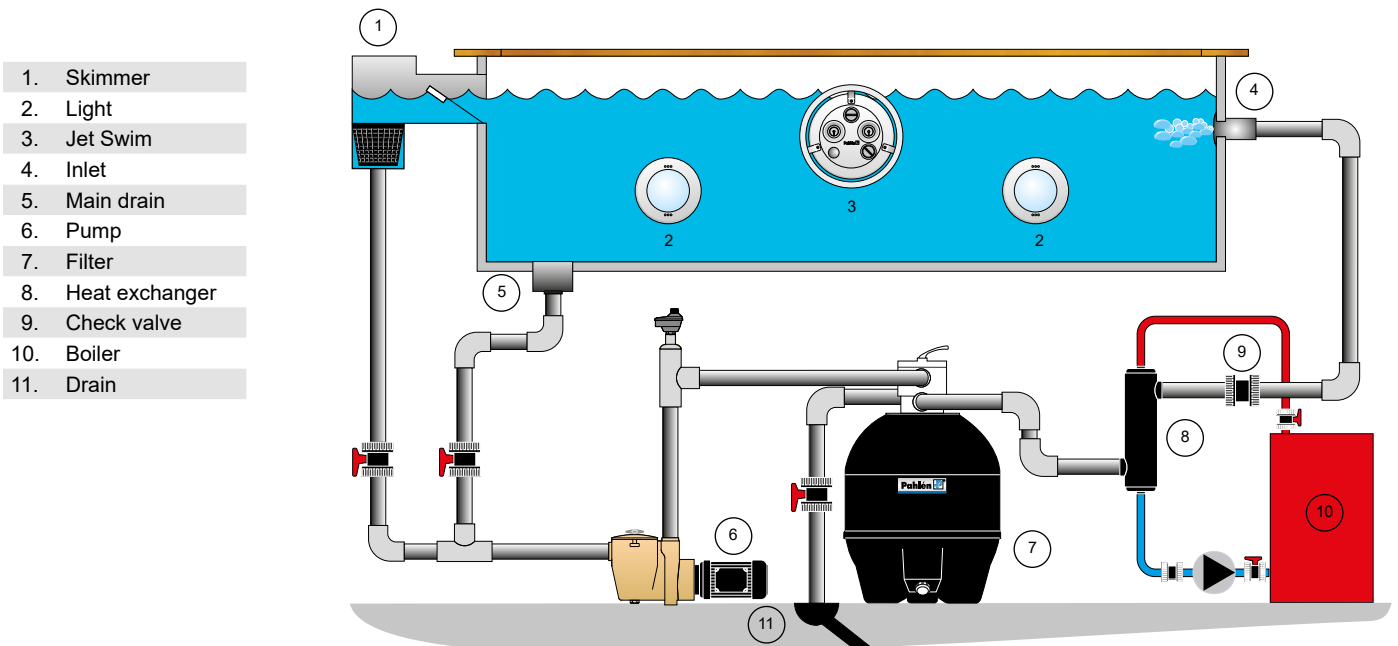
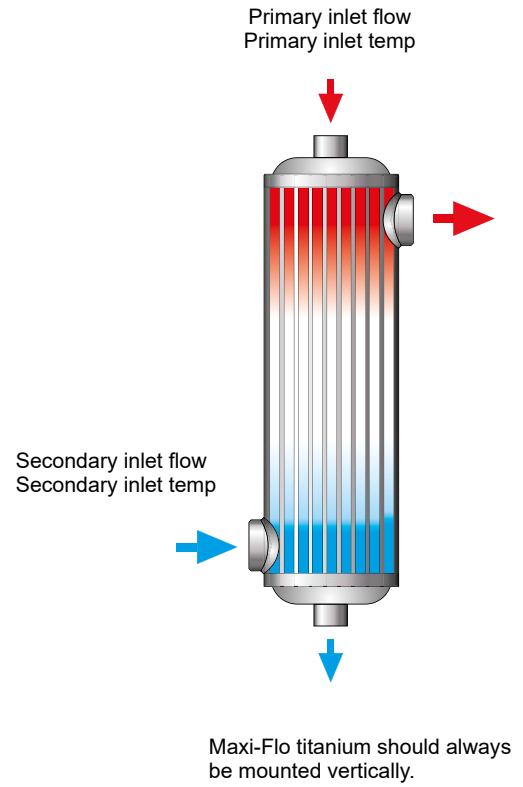
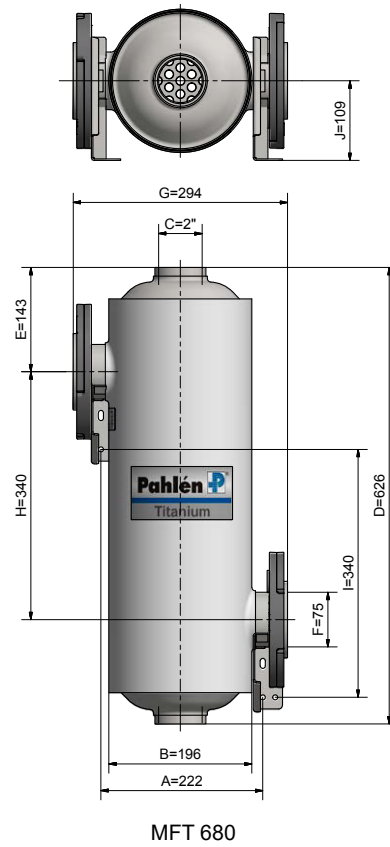
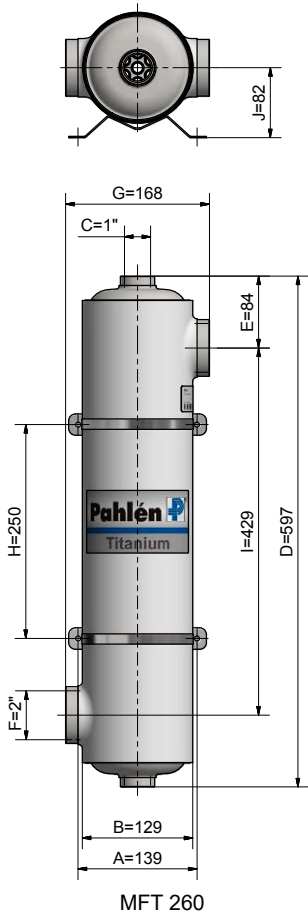

Heating - Heat exchangers



Maxi-Flo 40-120kW

Maxi-Flo is a tube heat exchanger with excellent heating properties. It is made of acid proof stainless steel EN 1.4404 for optimum durability. Simple installation using the stainless steel adjustable attachments that are included.

Maximum pressure secondary circuit (pool water) is 5 bar and primary circuit (hot water) is 10 bar. Suitable for pools up to 450 m³

Features

- Acid proof stainless steel EN 1.4404
- Precision-welded outer jacket
- 37 seamless pipes equipped with flow restrictors for hot water
- Adjustable brackets of acid proof stainless steel
- Four sizes: 40, 60, 75 and 120 kW
- Connects to existing heat source
- Can be connected in series when needed.
- Mounted vertically

Maxi-Flo is a tube heat exchanger with excellent heating properties, made of acid proof stainless steel for optimum durability.

Technical data

Item no.	Type	kW	Capacity		Primary, hot water		Secondary, pool water		kg
			kBtu/h	kcal	l/min	press. drop H (m)	l/min	press. drop H (m)	
11365	MF135	40	135	34 394	25	0.05	200	0.8	3.4
11366	MF200	60	200	51 590	30	0.15	250	1.4	4.5
11367	MF260	75	260	64 488	35	0.4	300	1.0	5.6
11368	MF400	120	400	103 181	50	0.5	360	1.5	9.3
10083002	Coupling 2" in case of series connection of 11367 or 11368.								1.3

Capacity at a temperature difference of 60°C

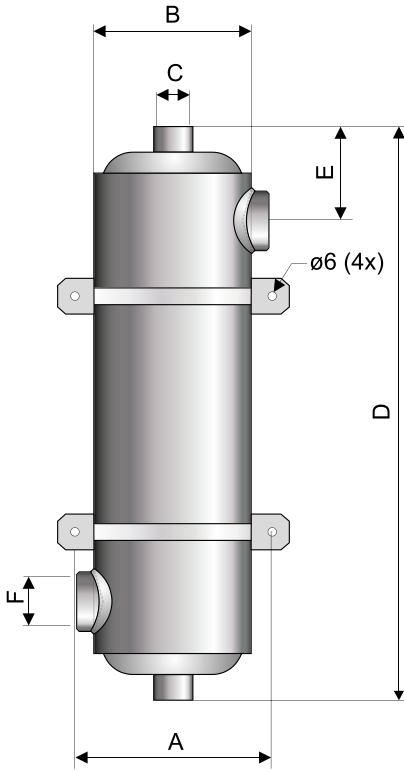
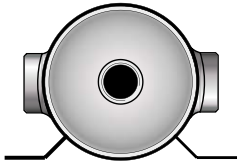

Dimensions

Item no.	kW	A	B	C	D	E	F
11365	40	139	129	1"	355	92	1½"
11366	60	139	129	1"	485	92	1½"
11367	75	139	129	1"	600	85	2"
11368	120	139	129	1½"	1070	85	2"

Example of Maxi-Flo connected in series

Maxi-Flo can be connected in series when needed.
Item no for coupling 10083002.

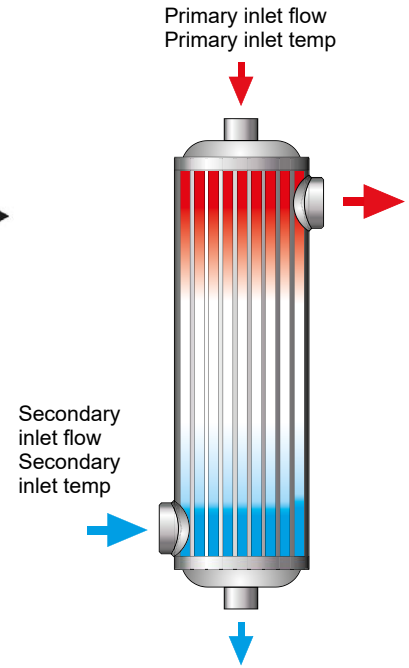
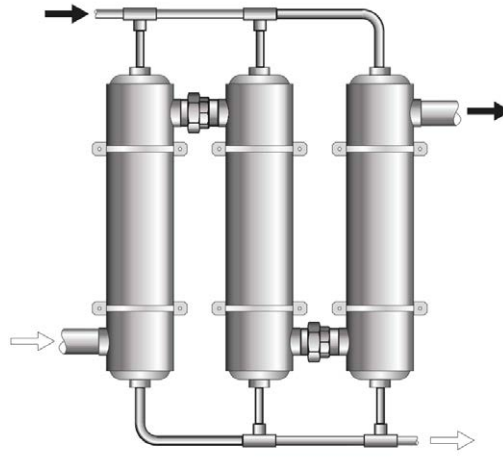

Maxi-Flo should always be mounted vertically.

1. Skimmer
2. Light
3. Jet Swim
4. Inlet
5. Main drain
6. Pump
7. Filter
8. Heat exchanger
9. Check valve
10. Boiler
11. Drain

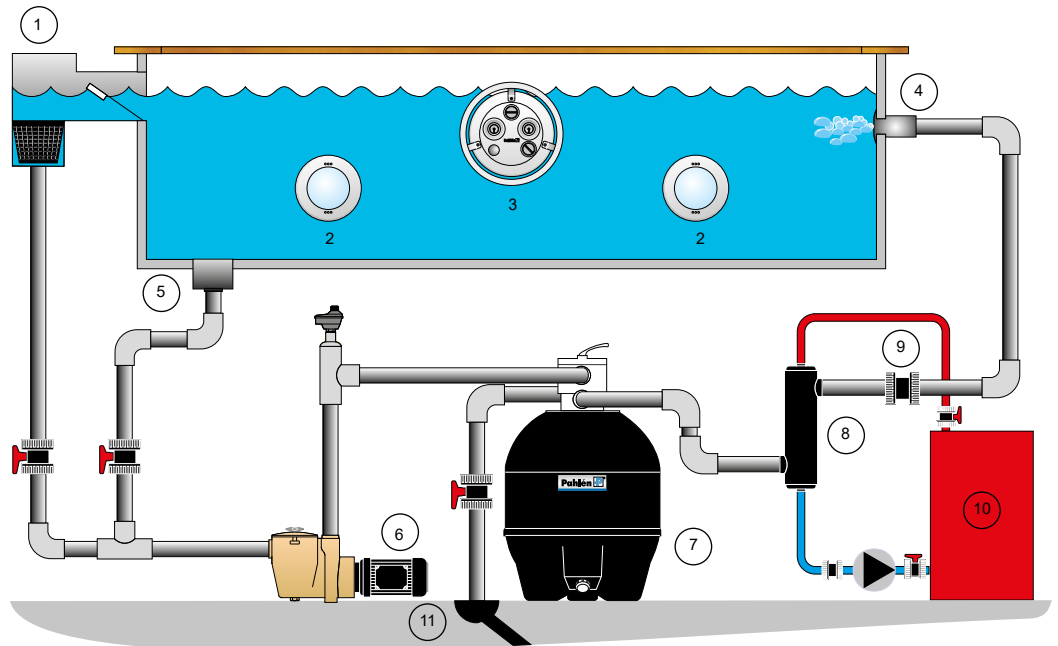

Heating - Heat exchangers



Hi-Flow titanium 28-75kW

Hi-Flow titanium is a spiral heat exchanger made of titanium for the most demanding installations where there is a high risk of corrosion. Titanium is ideal for swimming pools with salt water or when a salt chlorinator is used. Adjustable stainless steel attachments included.

Maximum pressure secondary circuit (pool water) is 5 bar and primary circuit (hot water) is 30 bar. Suitable for pools up to 300 m³

Features

- Titanium
- Connections with interior thread (secondary side)
- Coil for the heating medium
- Pocket for temperature probe
- Adjustable brackets of acid proof stainless steel
- Three sizes 28, 40 and 75 kW
- Connects to existing heat source
- Mounted horizontally

Hi-Flow is a spiral heat exchanger made of titanium, the ideal material when a salt chlorinator is used. Suitable for installations with high pressure.

Technical data

Item no.	Type	kW	Capacity		Primary, hot water		Secondary, pool water		kg
			kBtu/h	kcal	l/min	press. drop H (m)	l/min	press. drop H (m)	
11332	T28	28	95	24 075	20	1.0	300	1.1	1.9
11333	T40	40	135	34 393	40	2.3	350	1.7	2.0
11334	T75	75	260	64 488	45	5.2	350	1.7	2.9

Capacity at a temperature difference of 60°C for 11332 and 11333. Capacity at a temperature difference of 70°C for 11334.

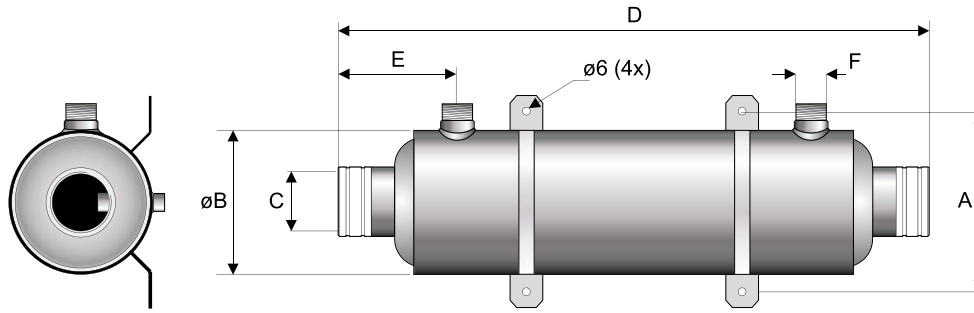

Dimensions

Item no.	kW	A	B	C	D	E	F	G
11332	28	139	113	1 ½"	470	95	1"	51
11333	40	139	127	1 ½"	510	108	1"	51
11334	75	139	127	1 ½"	754	108	1"	51

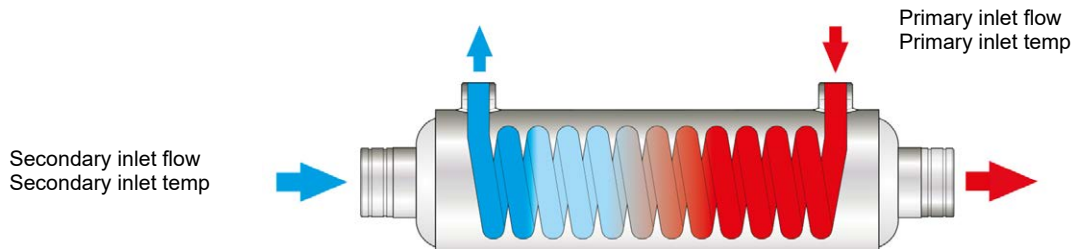

Hi-Flow titanium should always be mounted horizontal.

1. Skimmer
2. Light
3. Jet Swim
4. Inlet
5. Main drain
6. Pump
7. Filter
8. Heat exchanger
9. Check valve
10. Boiler
11. Drain

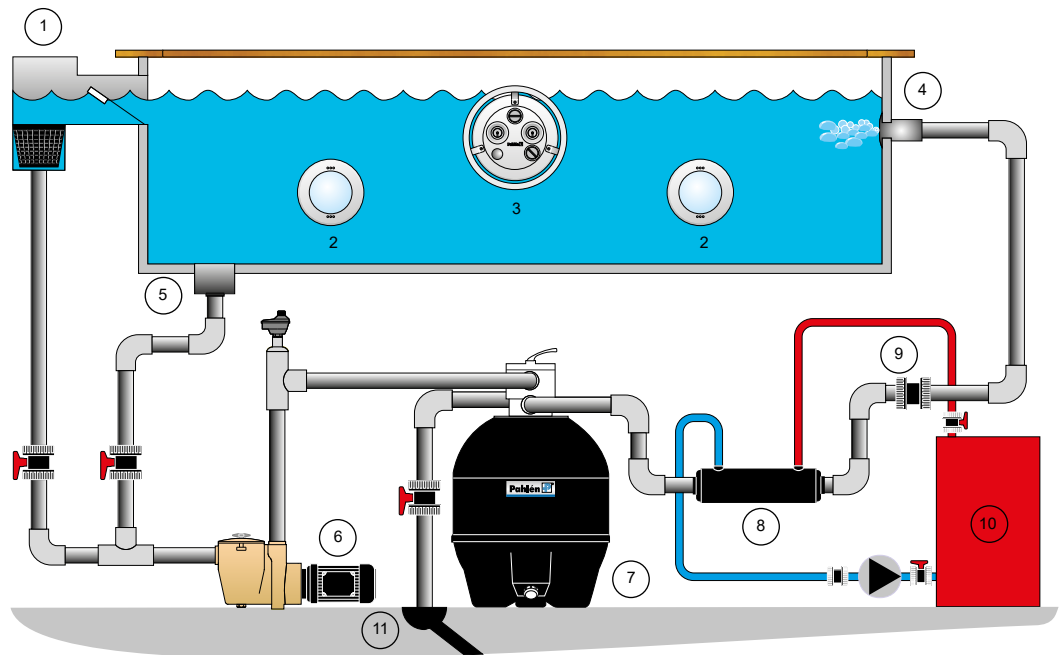



Hi-Flow 13-75kW

Hi-Flow is a spiral heat exchanger made of acid proof stainless steel EN 1.4404 for installations that operate under high pressure. Simple installation with the included adjustable stainless steel attachments.

Maximum pressure secondary circuit (pool water) is 8 bar and primary circuit (hot water) is 30 bar. Suitable for pools up to 300 m³

Features

- Acid proof stainless steel EN 1.4404
- Precision-welded outer jacket
- Coil for heating medium
- Pocket for temperature probe
- Adjustable brackets of acid proof stainless steel
- Four sizes: 13, 28, 40 and 75 kW
- Connects to existing heat source
- Mounted horizontally

Hi-Flow is a spiral heat exchanger for installations with high pressure made of stainless steel for optimal durability.

Technical data

Item no.	Type	kW	Capacity		Primary, hot water		Secondary, pool water		kg
			kBtu/h	kcal	l/min	press. drop H (m)	l/min	press. drop H (m)	
11391	HF13	13	45	11 177	25	0.9	200	0.6	1.9
11392	HF28	28	95	24 075	25	1.7	300	1.6	3.2
11393	HF40	40	135	34 393	60	1.3	300	1.6	3.4
11394	HF75	75	260	64 488	60	2.6	300	1.1	5.3

Capacity at a temperature difference of 60°C for 11391 and 11392. Capacity at a temperature difference of 70°C for 11393 and 11394.

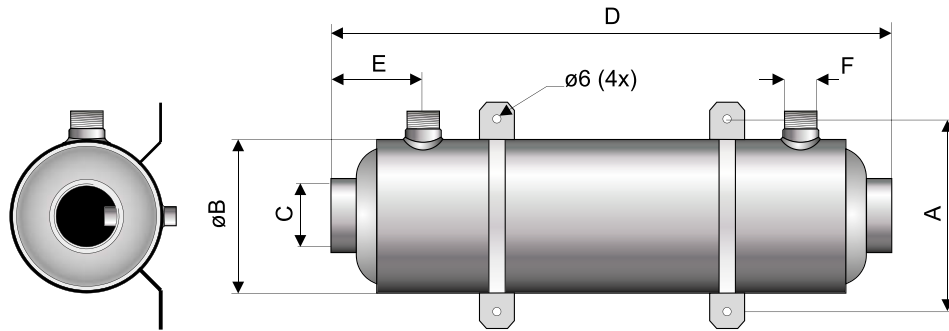

Dimensions

Item no.	kW	A	B	C	D	E	F
11391	13	139	129	1 ½"	235	72	¾"
11392	28	139	129	1 ½"	407	75	¾"
11393	40	139	129	1 ½"	455	85	1"
11394	75	139	129	2"	702	85	1"

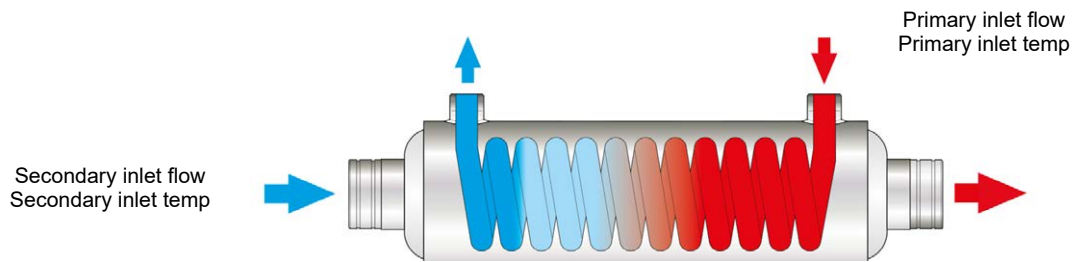

Hi-Flow should always be mounted horizontal.

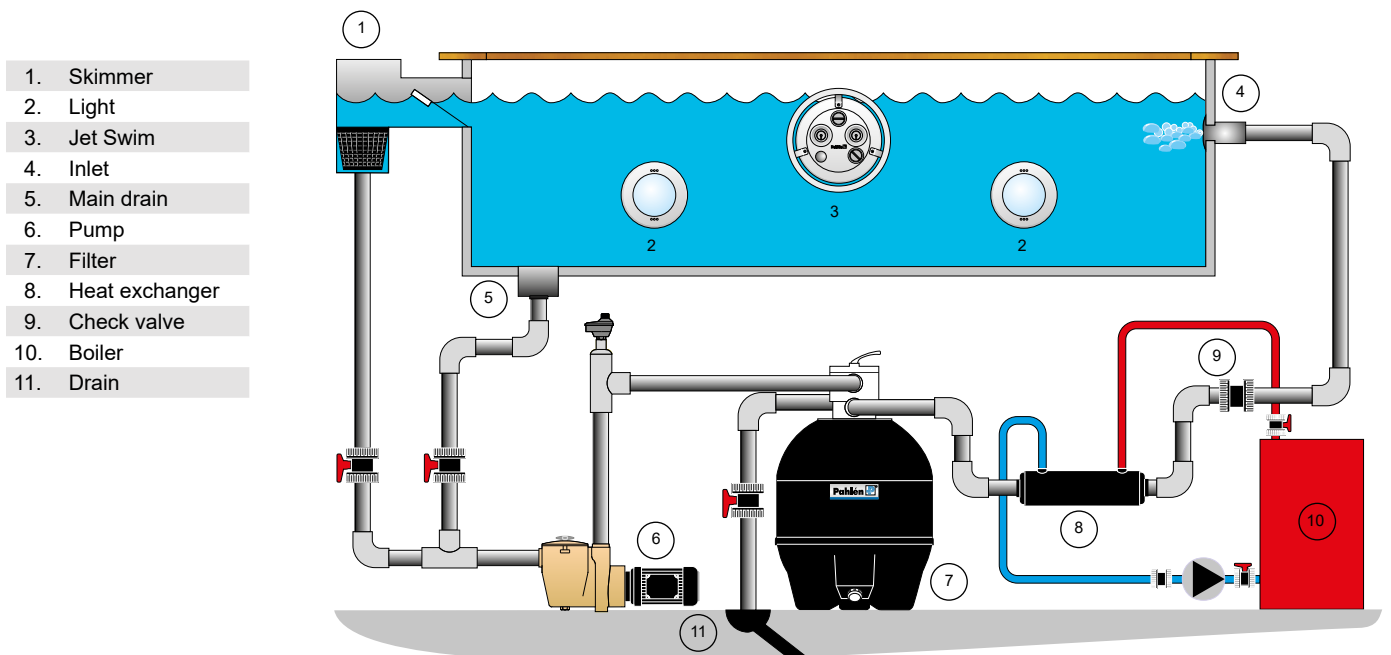

Heating - Heat exchangers



Hi-Temp titanium 40-75kW

Hi-Temp titanium is a spiral heat exchanger made of thermoplastic with a high glass content for extra durability. With a coil of titanium for the most demanding installations where there is a high risk of corrosion, such as in pools with salt water or where a salt chlorinator is used.

Maximum pressure secondary circuit (pool water) is 4 bar and primary circuit (hot water) is 5 bar. Suitable for pools up to 300 m³.

Features

- Outer jacket of thermoplastic
- Hot water coil made of titanium
- Integrated wall-mounting
- Slip connections for bonding of Ø 50 mm pipes
- Two sizes 40 and 75kW
- Connects to existing heat source
- Mounted horizontally or vertically

Hi-Temp titanium is a spiral heat exchanger made of thermoplastic with a high glass content for extra durability and titanium.

Technical data

Item no.	Type	kW	Capacity		Primary, hot water		Secondary, pool water		kg
			kBtu/h	kcal	l/min	press. drop H (m)	l/min	press. drop H (m)	
11322	HTT 40	40	135	34 393	52	1.5	300	1.1	2.3
11324	HTT 75	75	260	64 488	58	2.5	300	1.2	3.5

Capacity at a temperature difference of 60°C

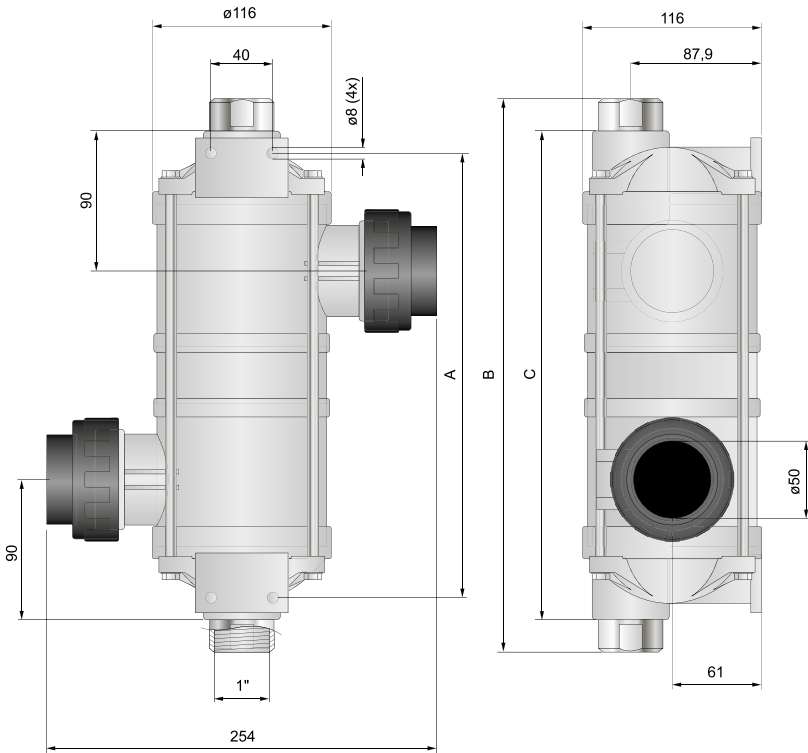

Dimensions

Item no.	kW	A	B	C
11322	40	418	375	277
11324	75	670	625	452

Also available with connections 1 1/2" pipe or 1 1/2" threaded, on secondary side.

1. Skimmer
2. Light
3. Jet Swim
4. Inlet
5. Main drain
6. Pump
7. Filter
8. Heat exchanger
9. Check valve
10. Boiler
11. Drain

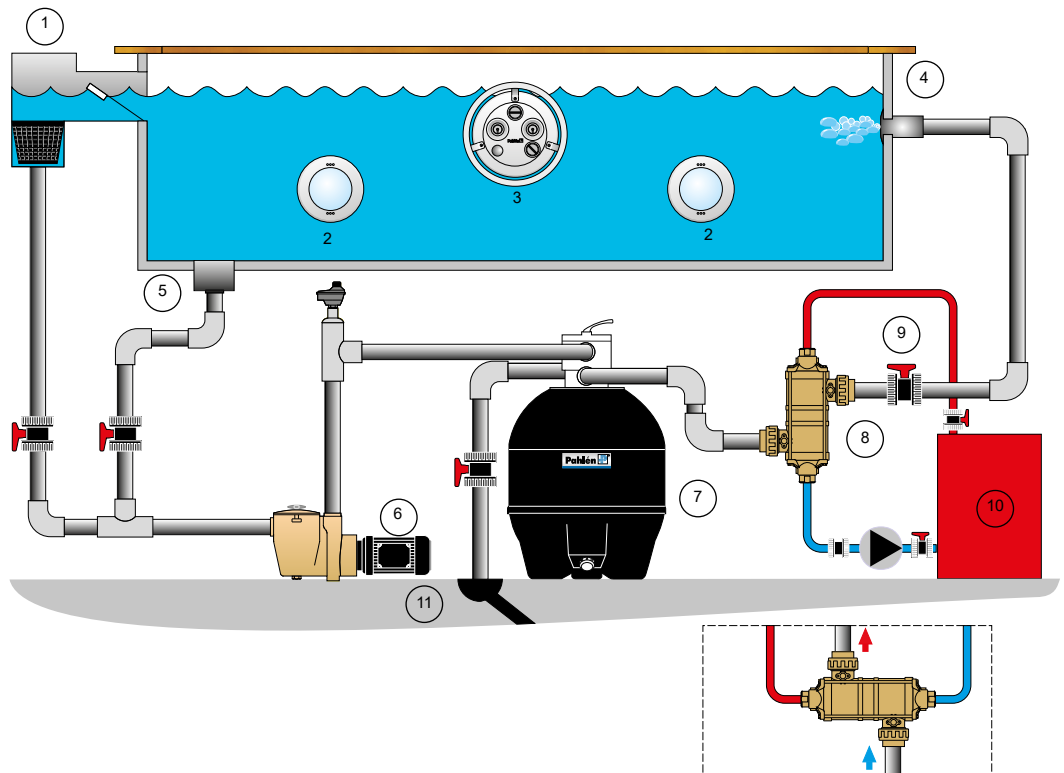

Heating - Heat exchangers



Hi-Temp 40-75kW

Hi-Temp is a spiral heat exchanger made of thermoplastic with a high glass content for extra durability, and with a coil of acid proof stainless steel EN 1.4404.

Maximum pressure secondary circuit (pool water) is 4 bar and primary circuit (hot water) is 5 bar. Suitable for pools up to 300 m³.

Features

- Outer jacket of thermoplastic
- Hot water coil made of acid proof stainless steel
- Integrated wall-mounting
- Slip connections for bonding of Ø 50 mm pipes
- Two sizes 40 and 75 kW
- Connects to existing heat source
- Mounted horizontally or vertically

Hi-Temp is a spiral heat exchanger made of thermoplastic with a high glass content for extra durability.

Technical data

Item no.	Type	kW	Capacity		Primary, hot water		Secondary, pool water		kg
			kBtu/h	kcal	l/min	press. drop H (m)	l/min	press. drop H (m)	
11312	HT40	40	135	34 393	34	1.9	300	1.3	1.8
11314	HT75	75	260	64 488	43	5.5	300	1.7	2.3

Capacity at a temperature difference of 60°C

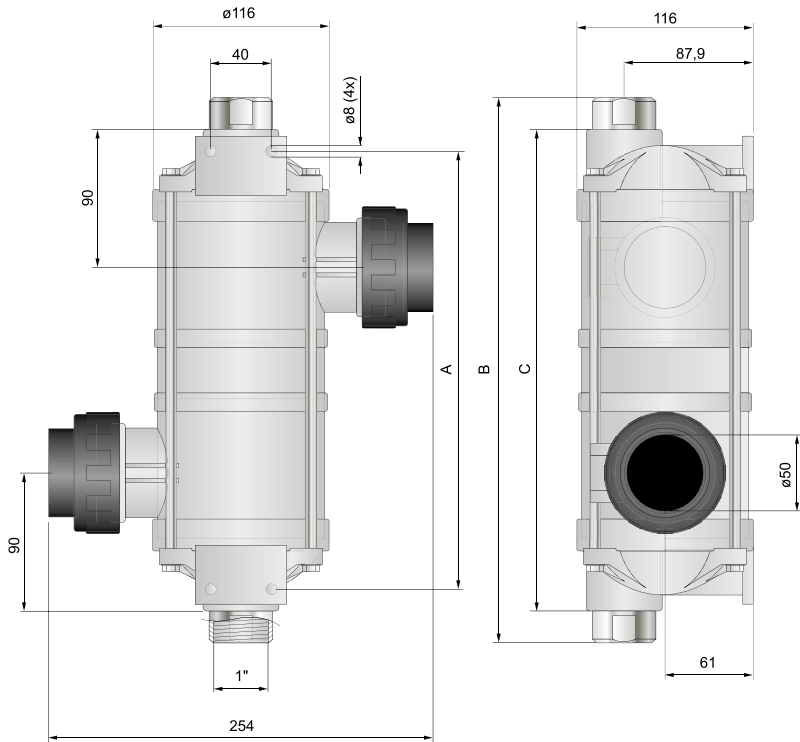

Dimensions

Item no.	kW	A	B	C
11312	40	277	360	315
11314	75	454	535	492

Also available with connections 1 1/2" pipe or 1 1/2" threaded, on secondary side.

1. Skimmer
2. Light
3. Jet Swim
4. Inlet
5. Main drain
6. Pump
7. Filter
8. Heat exchanger
9. Check valve
10. Boiler
11. Drain

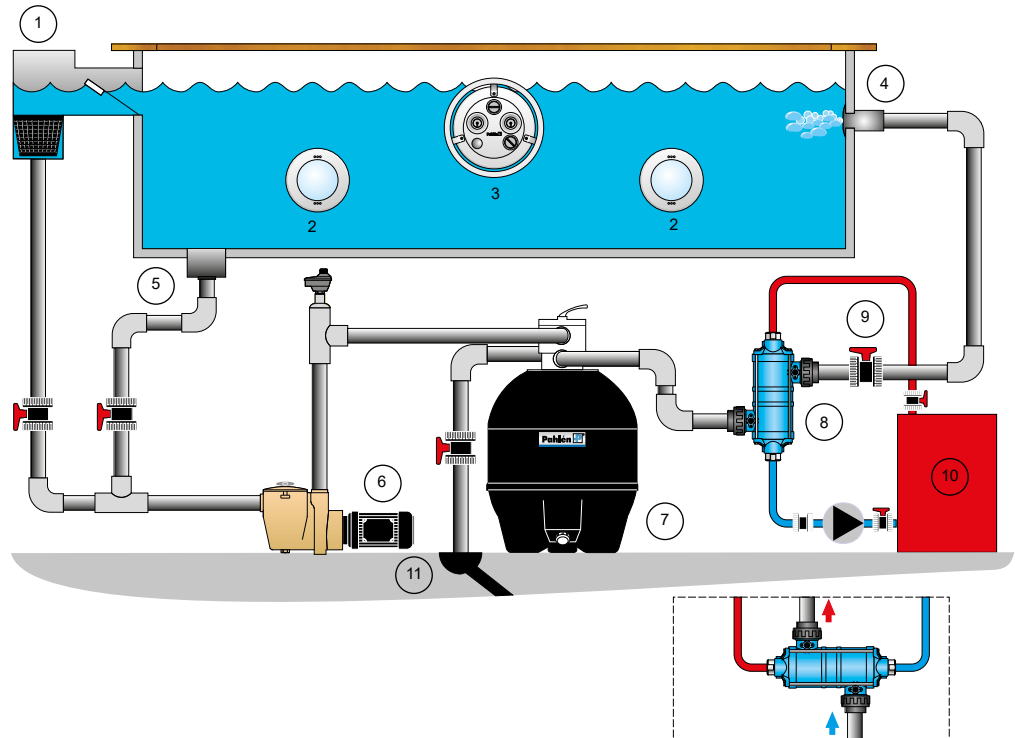

Heating - Heat exchangers



Aqua MEX

Aqua MEX is made of high quality materials, fibreglass reinforced polypropylene and a high effective coil made of titanium. Our line gives the best possible heating capacity and resistance against aggressive water. Aqua MEX is compact, fully equipped, easy to install and use. The heat exchanger has a straight flow with a low pressure drop and with slip connections for Ø 63 mm pipes.

Maximum pressure secondary circuit (pool water) is 4 bar and primary circuit (hot water) is 6 bar.

Features

- Aqua MEX fully equipped comes complete with flow switch, check valve, temperature sensor, three-step single-phase circulation pump and electronics
- Economic - lower installation and operation costs
- Capacity range 40, 70kW. Standard also available as 100kW
- Digital control and display
- The housing and cabinet are made of fibreglass reinforced polypropylene
- Straight flow Ø 63 mm (2") pipe
- Coil made of titanium or stainless steel EN 1.4404
- Connects to existing heat source
- IP44 (International Protection Rating)
- Standard version without controller and pump
- Mounted horizontally

Aqua MEX is a compact spiral heat exchanger of highest quality.

Item no. with T refers to the Aqua MEX with a coil of titanium.

Technical data

Item no.	Fully equipped	Item no.	Standard	Capacity			Primary, hot water		Secondary, pool water	
				kW	kBtu/h	kcal	l/min	press. drop H (m)	l/min	press. drop H (m)
113951	AM-FE40	11316	AM40	40	135	34 393	20	0.6	250	0.4
113952	AM-FE40T	11326	AM40T	40	135	34 393	20	0.4	250	0.5
113953	AM-FE70	11317	AM70	70	240	60 200	30	1.6	300	0.5
113954	AM-FE70T	11327	AM70T	70	240	60 200	30	1.4	300	0.6
		11318	AM100	100	340	86 000	40	2.5	340	0.7
		11328	AM100T	100	340	86 000	40	2.3	340	0.8

Capacity at a temperature difference of 60°C

Fully equipped version 40 and 70kW

Aqua MEX fully equipped has a three-step single-phase built-in circulation pump for the primary (hot) water as well as built-in temperature sensor, flow switch and check valve. Digital temperature control and display.

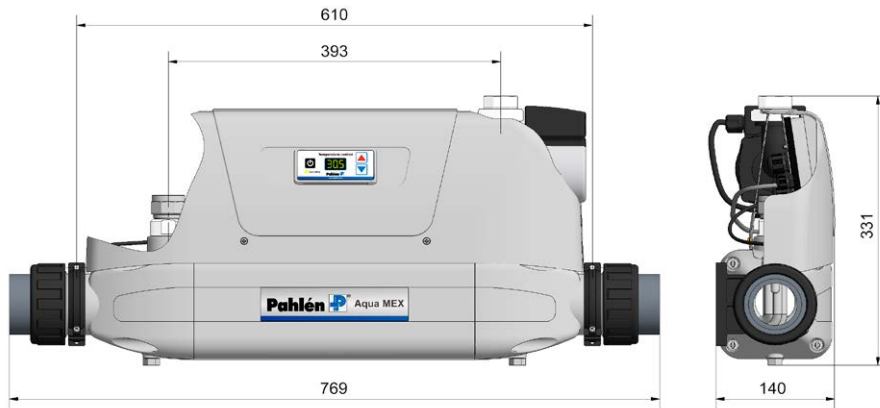

Item no.	Kg
113951	9.1
113952	8.4
113953	9.7
113954	8.8

Standard version 40, 70 and 100kW.

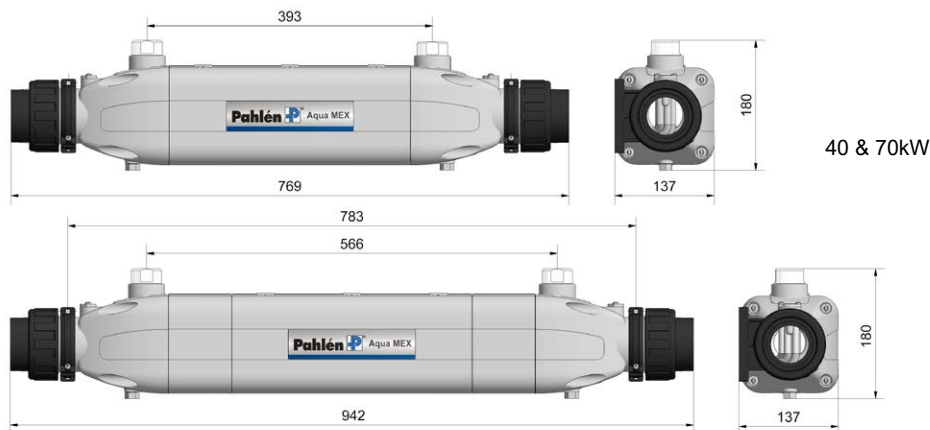

Item no.	Kg
11316	4.8
11326	3.9
11317	5.5
11327	4.2
11318	7.3
11328	5.6

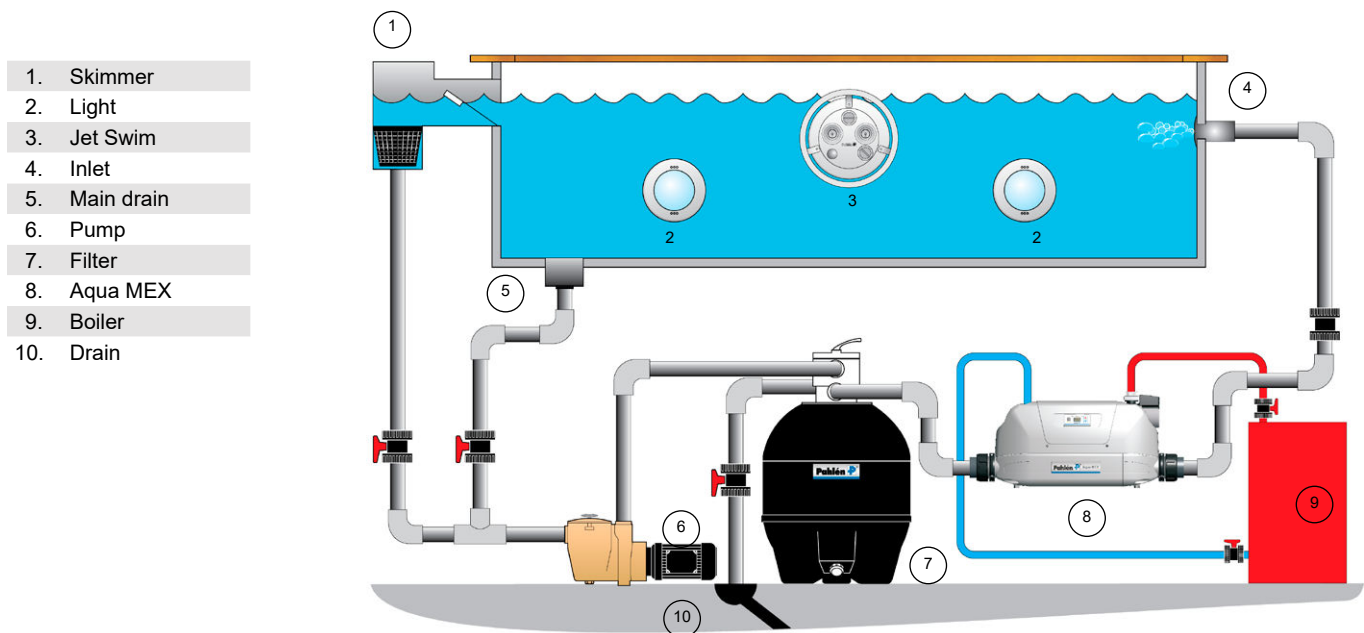

1. Skimmer
2. Light
3. Jet Swim
4. Inlet
5. Main drain
6. Pump
7. Filter
8. Aqua MEX
9. Boiler
10. Drain

Heating - Heat exchangers



MidiTemp

A compact unit for digital setting and viewing of temperature for operation and control of heating products, both in already existing or new installations. Control panel with on/off mode and programmable set value 5 - 45°C. The controller has an input for external flow switch and/or overheating limit control. 230V output for operating a wide range of heating applications; heat exchangers, solar panels, electric heaters etc.

The controller will give a more precise temperature regulation compared to an analogue thermostat. Built-in safety features for overheat protection, flow switch for low pool circulation and alarm for temperatures above 45°C. Provides a safe operation for both users and pool components.

Item no.

128470 MidiTemp

Features

- Electronic control panel with LED
- Remote view and control
- Precise temperature setting
- Controller output gives 230V (max 1A) to control a variety of heating applications; e.g. pumps, contactors, valves etc.
- Length of sensor cable 1400 mm
- Built-in protection and alarm against excessive temperature or sensor failures
- Flow switch input with time-delayed output - heating aborted with alarm when reached low pool circulation

..... Digital view and precise control of
..... pool water temperature

Technical data	
Power connection	220-240VAC 1~N 50Hz
Max effect	230W
Sealing class	IP44
Dimensions L x W x H	170 x 50 x 160 mm
Connection cabel	3 x 0,75 mm ² , 1.5 m long
Switch on at 0.5°C under set temperature	
Switch off 0.5°C above set temperature	
Connections	
Control voltage	230 VAC 50Hz max 1A
Protection switches	Potential free contacts

Electronic digital control panel

- Built-in safety features for overheat protection for temperatures above 45°C
- Energy efficient
- Easy to set desired temperature
- Clear digits show the pool temperature and the set temperature
- Indicates when heater is operating



Sensor well/Saddle clamp



Flow switch

Accessories

Item no.

14009100	Sensor well R1/2" L=70 mm
128604	Saddle clamp 63 x 1/2" PN10 PP
12870	Flow switch, external connection 1/2"

Thermostat for setting and automatic control of water temperature.

Item no.	Temperature range	Connection
12840	0-40°C	1/2"

Equipped with probe 160 mm.



Thermostat



Pahlén AB

Box 728, 194 27 Upplands Väsby, Sweden
Email: info@pahlen.se, www.pahlen.com

We do not accept liability for printing errors.
We reserve the right to make changes to specification and product range.
Colour deviation may occur due to restrictions in the printing process.